

**Einbauanleitung Elektrosatz
Anhängervorrichtung mit 13-P Steckdose
lt. DIN/ISO Norm 11446**

**Instructions de montage du faisceau
électrique pour crochet d'attelage
conforme à la norme
DIN/ISO 11446 prise 13-P**

**Fitting instructions electric wiringkit
towbar with 13-P socket up to
DIN/ISO norm 11446**

**Montage-handleiding elektrokabelset voor
trekhaak met 13-P contactdoos
vlg. DIN/ISO norm 11446**

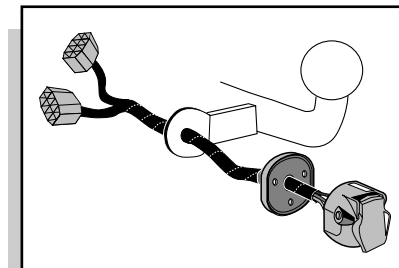

**MERCEDES W210/S210 1995-
CLK C208 1997-**

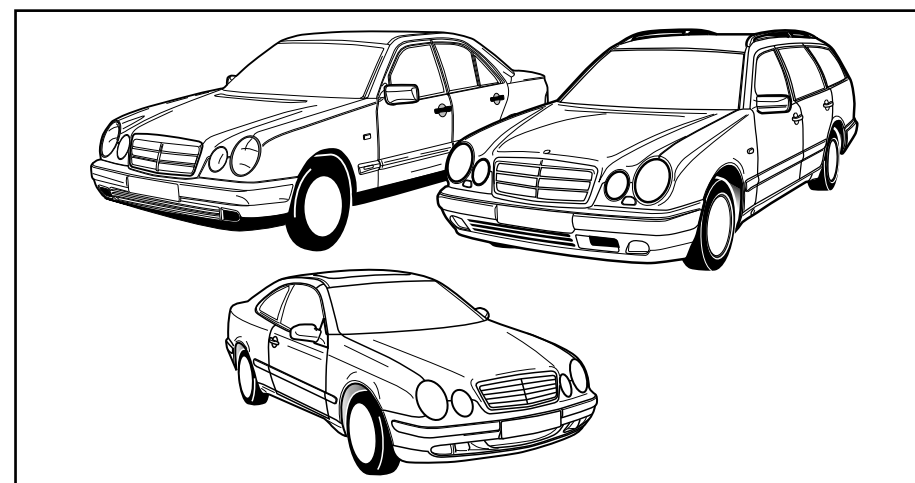

Bestel Nr.: MB-026-FL

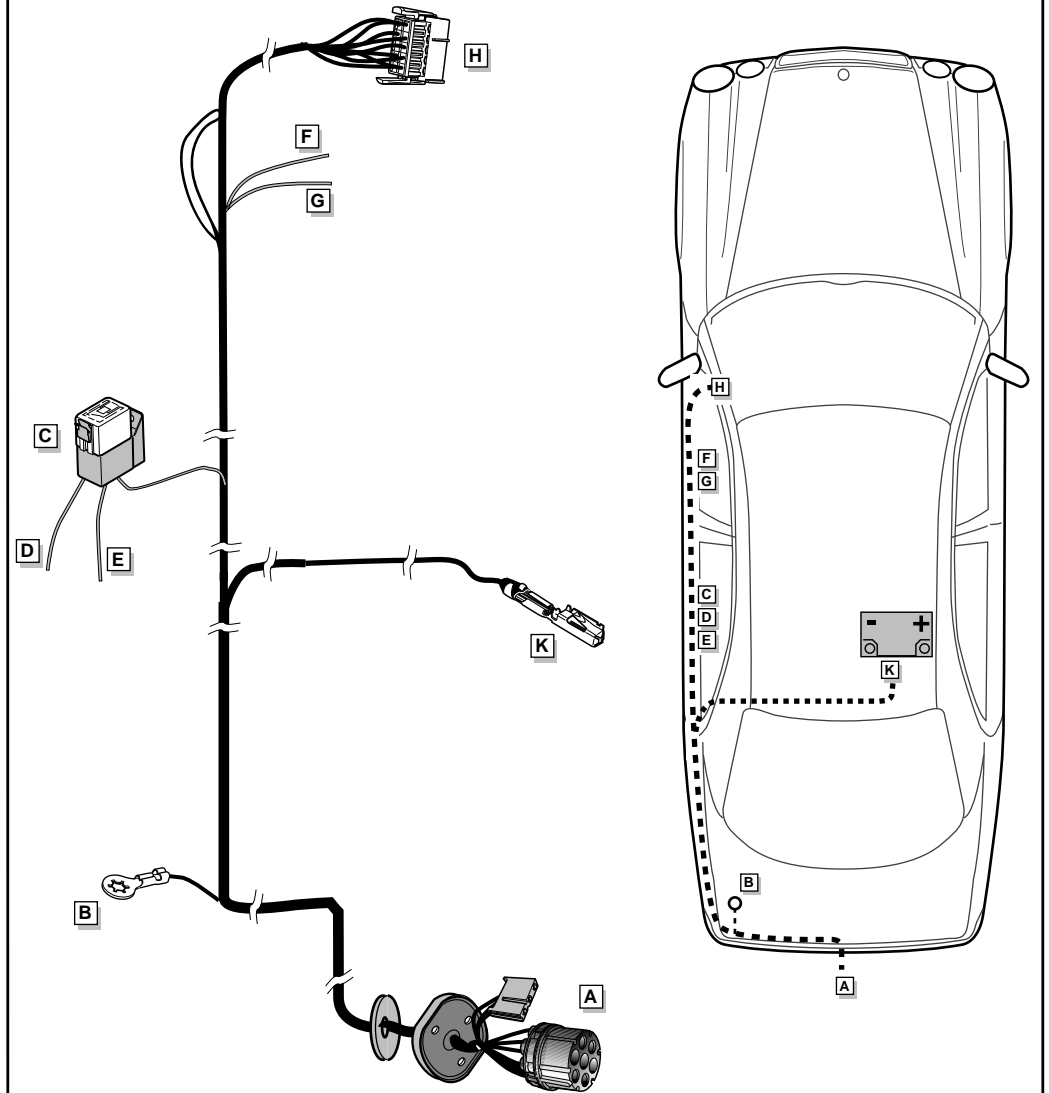

INFO & ROUTING C208

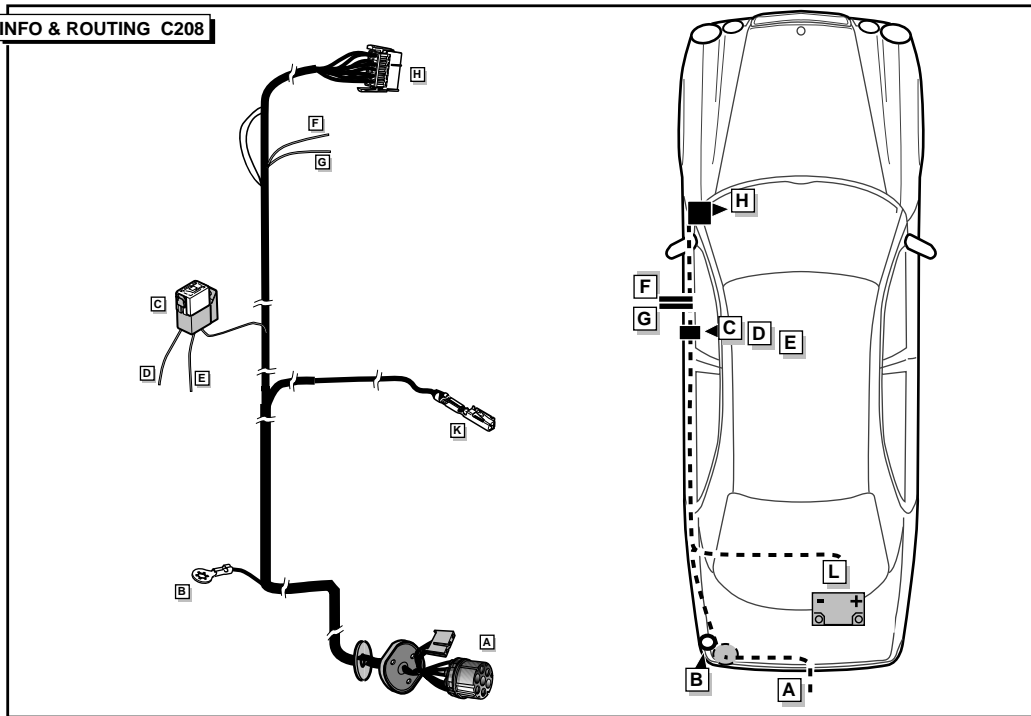

1 W210

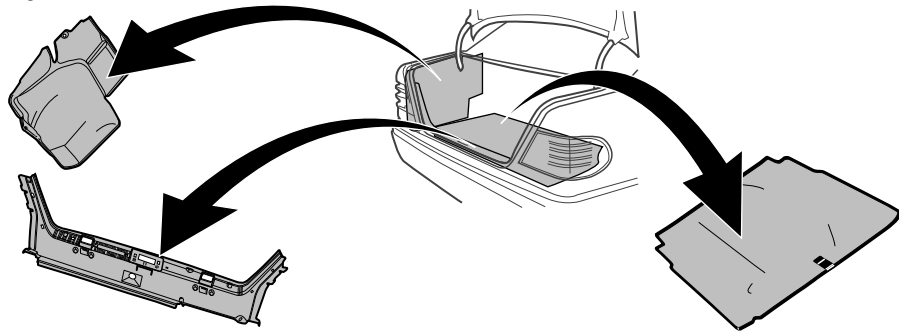

S210

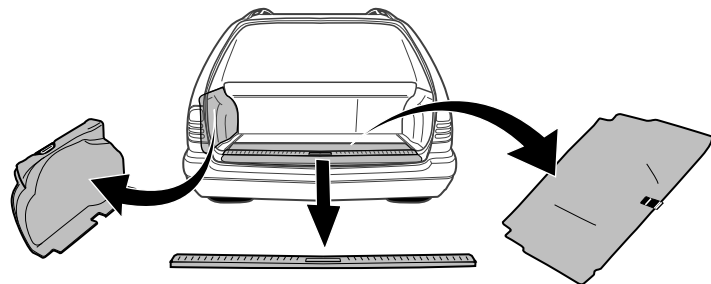

2 C208

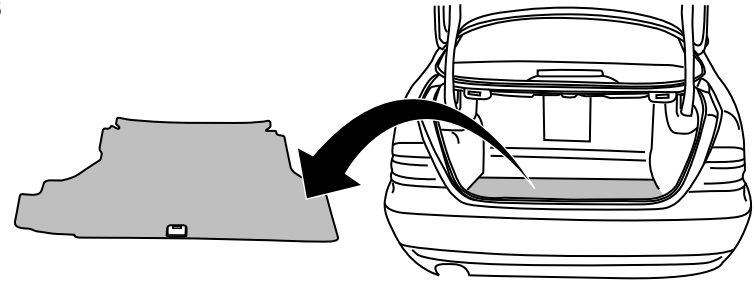

3 C208

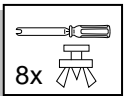
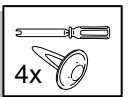
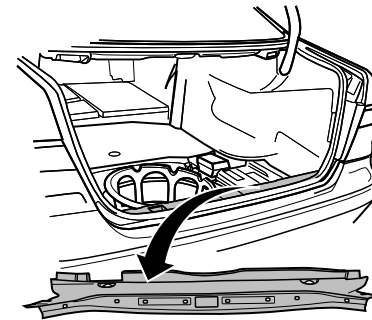

4 C208

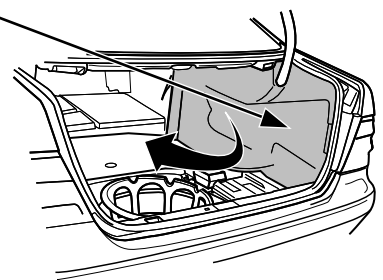
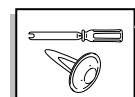

5 W210+S210

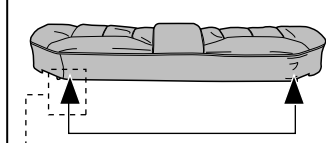
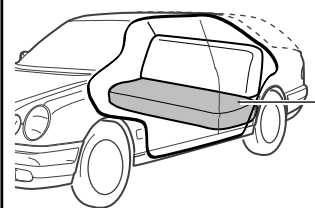

1

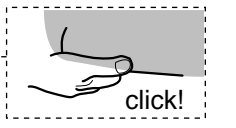

2

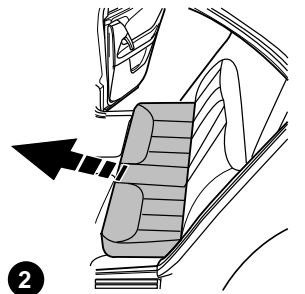

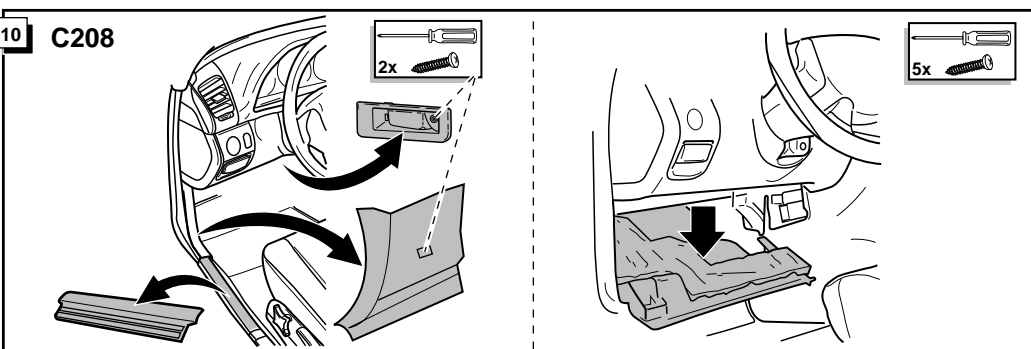
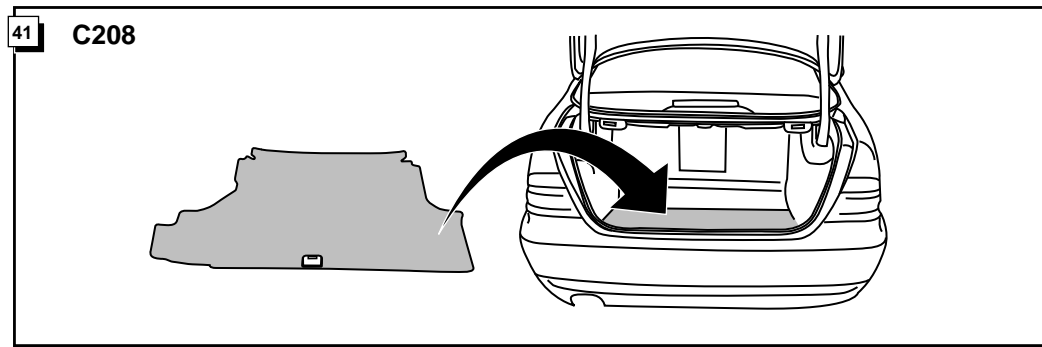
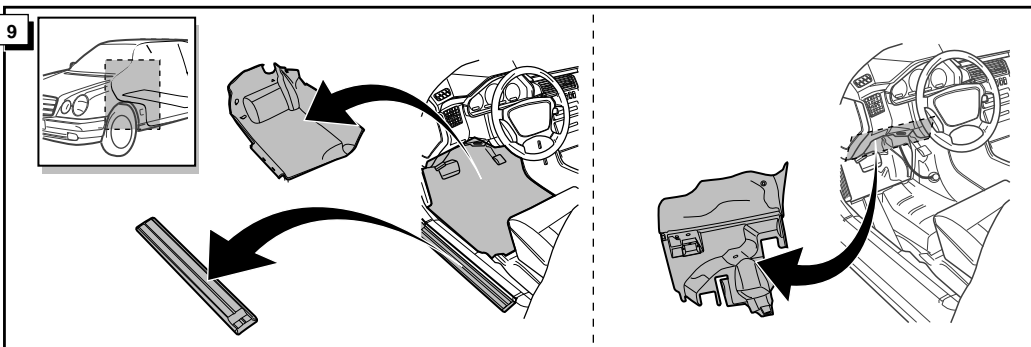
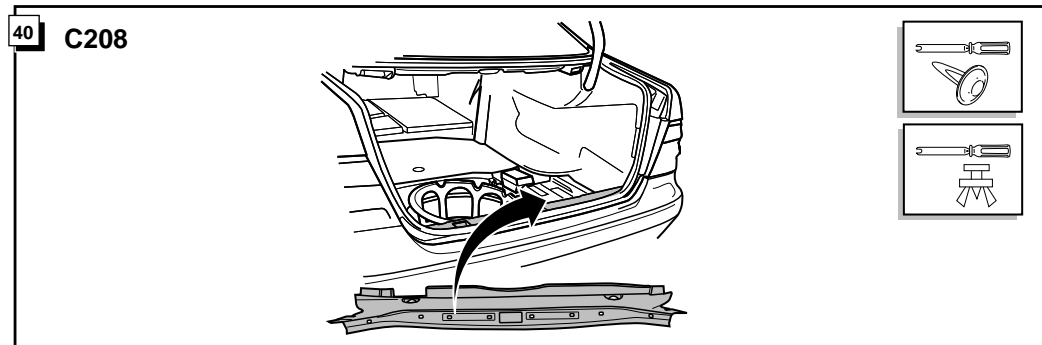
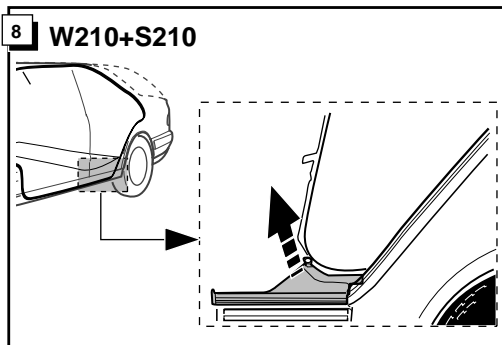
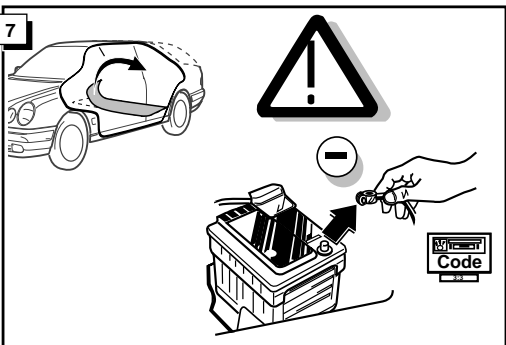
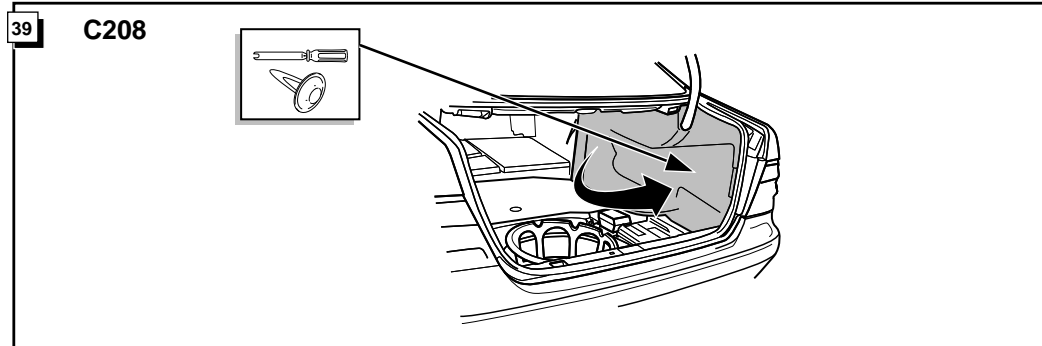
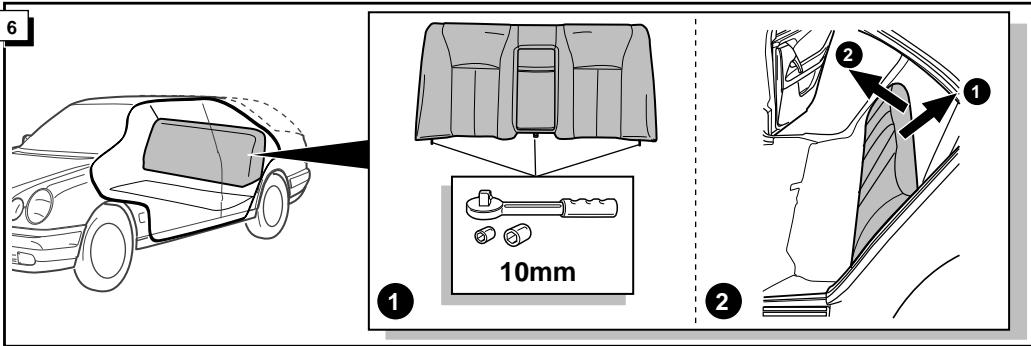

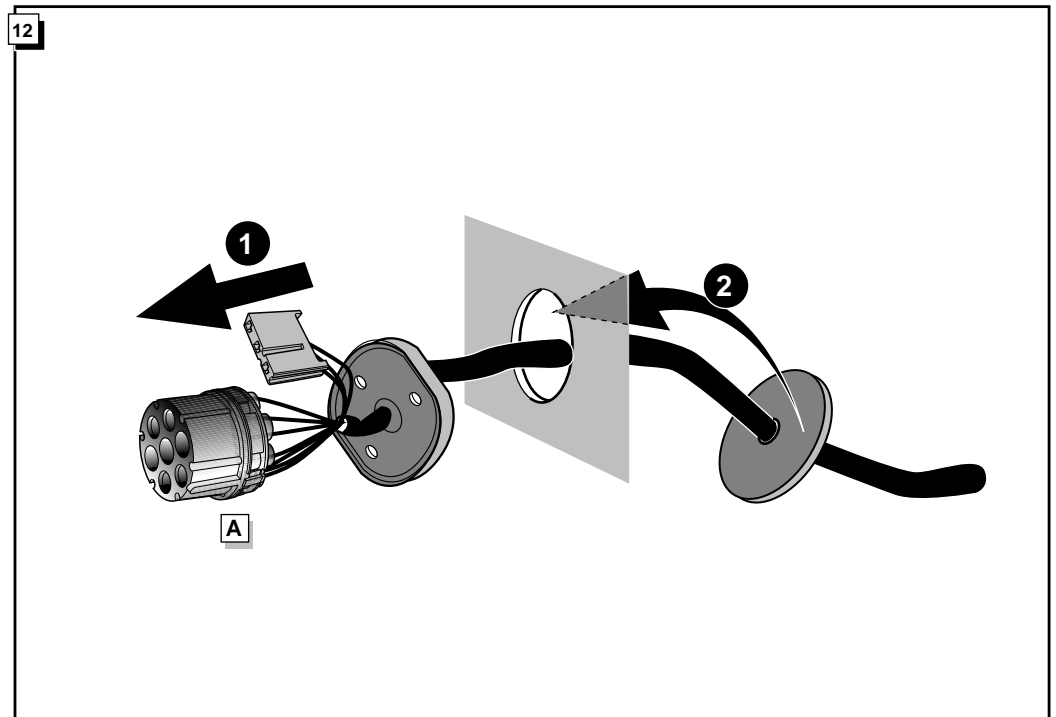
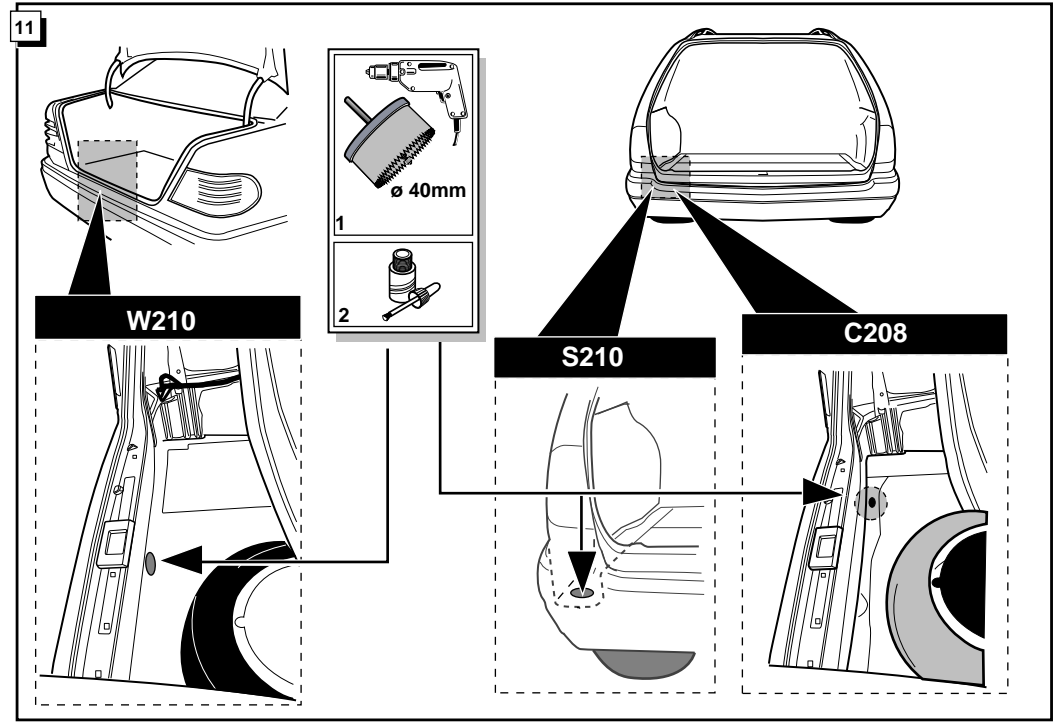
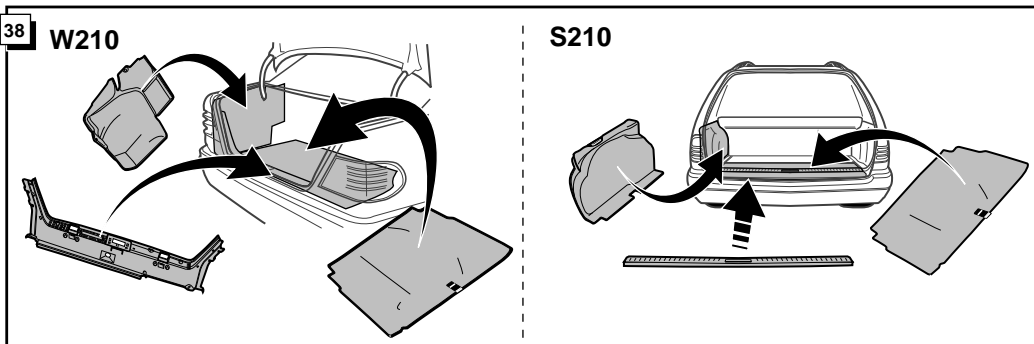
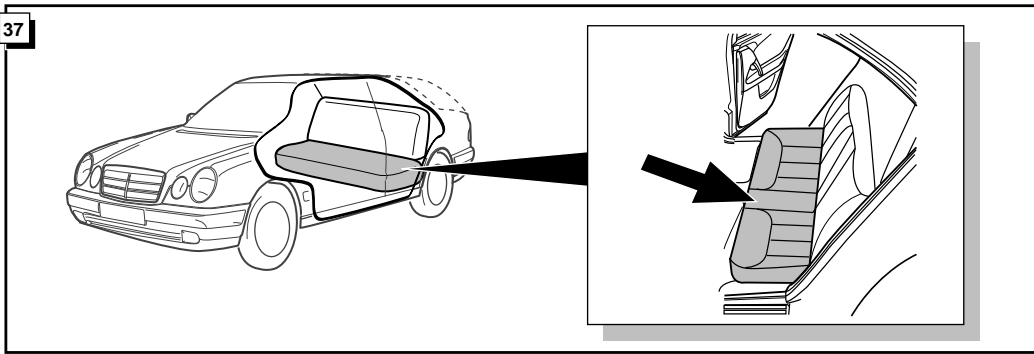
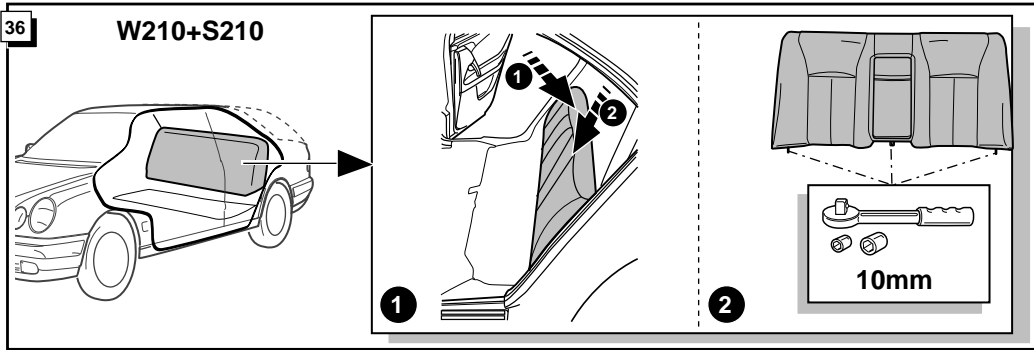
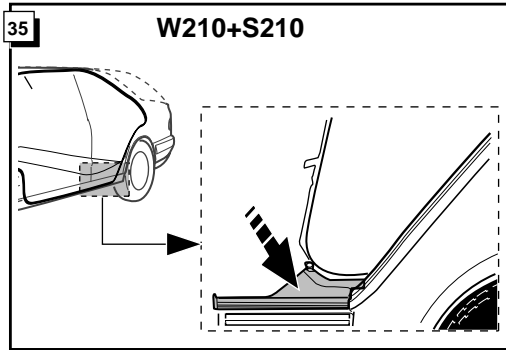
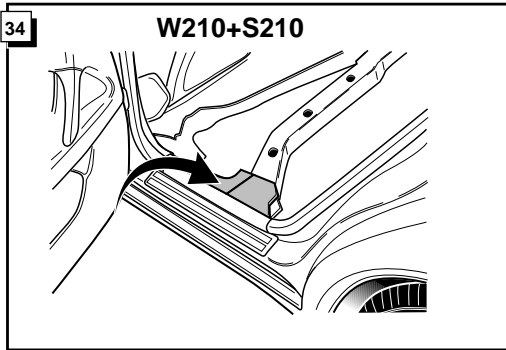

13

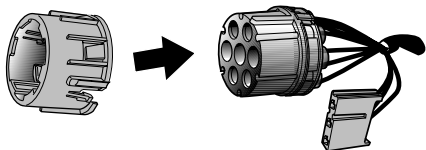

1

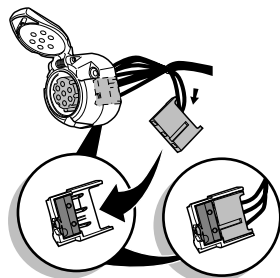

3

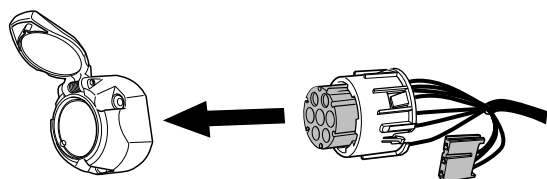

2

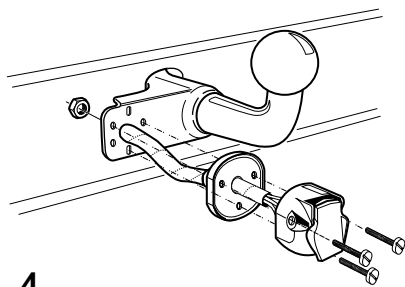

4

28

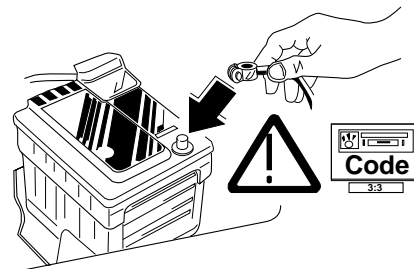

29

FUNKTIONEN KONTROLIEREN !
CONTRÔLER LES FONCTIONS !
CHECK FUNCTIONS!
CONTROLEER FUNCTIES !

30

*Das im Fahrzeug anwesende Relais funktioniert normal wie ein 2/4 x 21W Relais, aber wenn die Anhänger angeschlossen ist, funktioniert das Relais wie ein 2+1/6 x 21W Relais.

*Le relay d'origine fonctionne comme un relay de 2/4x21W. Avec le caravane accouplée le relay fonctionne comme un relay 2+1/6x21W.

*The original blinkerrelay functions normally as a 2/4x21W relay. Only if the trailer/caravan is connected it functions as a 2+1/6x21W.

*Het bestaande knipperrelais functioneert als een 2/4x21W relais. Als de aanhanger aangesloten is functioneert deze als een 2+1/6x21W relais.

INFO Anschluß Steckdose / Connection de la prise / Socket connection / Contactdoos aansluiting

DIN/ISO 1724		D	F	GB	NL
	1/L	gelb	jaune	yellow	geel
	2	blau	bleu	blue	blauw
	3/31	weiß	blanc	white	wit
	4/R	grün	vert	green	groen
	5/58-R	braun	marron	brown	bruin
	6/54	rot	rouge	red	rood
	7/58-L	schwarz	noir	black	zwart
		weiß	blanc	white	wit
		braun/weiß	marron/blanc	brown/white	bruin/wit

31

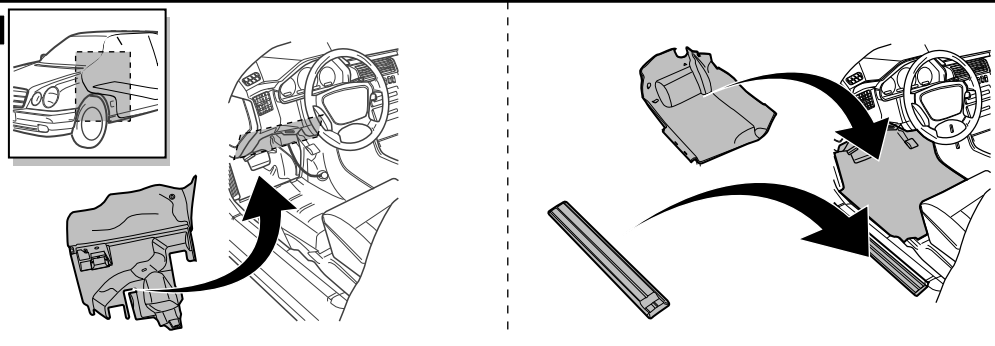

32

W210+S210

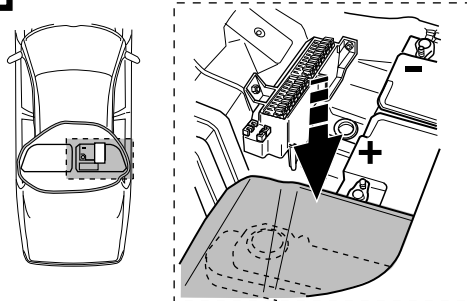

33

W210+S210

